

# **DRYWALL AND PANEL HOIST**



## **INSTRUCTION MANUAL**

# Introduction

The Drywall Lift allows one person to lift a drywall panel that is up to 122 x487CM in size or the small size 124X114cm, without assistance. The panel can be raised to a maximum height of 335CM for attachment to level ceilings-or (with the lift's cradle tilted) to sloped ceilings or side walls. For higher ceilings, an Extension Accessory is available that increases maximum lift to 470CM.

The Lift's cradle lowers to 86.4CM. off the floor for easy panel loading, and can support up to 68kgs.

These instructions explain how to assemble the Lift, operate it, disassemble it after use for easy transport and storage, and order replacement parts. We urge you to read the Important Precautions below, and the Operation sections, before trying to use the Lift.

## Important Precautions

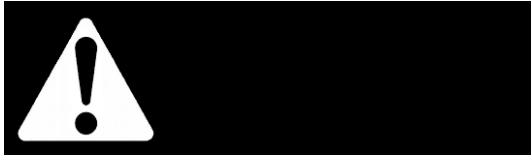

To protect against serious injury, use common sense and observe the following precautions when operating the Drywall Lift.

- ALWAYS study these instructions before operating, and pay close attention to all warnings.
- ALWAYS inspect the unit carefully before each day's use, pay special attention to the condition of the cable.
- ALWAYS allow the Lift to reach working room temperature before use (moving a cold unit into a warm room can cause condensation, which could affect the operation of the winch brake).
- Always be sure the brake drum is clean and dry before operating.
- NEVER use the Lift if either crossarm support is not secured by its locking spring tab.
- ALWAYS keep the work area free of obstructions.
- ALWAYS wear a hard hat when operating this Lift.
- ALWAYS watch for overhead obstructions when lifting the drywall panel.
- NEVER use the Lift for any purpose other than lifting a drywall panel.
- NEVER lift more than one sheet of drywall at a time. Never lift more than 68kgs.

## Contents

Assembly .....	2
Operator Controls .....	5
Operating Procedure .....	7
Disassembly .....	9
Maintenance .....	10
Extension Accessory .....	10
Parts Diagram .....	12
Parts List .....	13

# Assembly

## Components

The Drywall Lift is shipped as several components that must be assembled before use:

- Tripod base assembly.
- Frame assembly (138CM HIGH) , which includes a winch assembly and standard (122-cm) telescoping lift sections
- Cradle assembly, without its detachable crossarms
- Two cradle crossarm assemblies

## Assembly Procedure

1. Set up the tripod base:
  - a. Set the base on the floor, resting on its casters.
  - b. Press down on the slide yoke ring. Hold the ring down while you swing the two forward legs out until the yoke ring snaps or black place into the locking hole on the bottom of the slide tube. (See Figure 1)
  - c. To prevent the tripod base from rolling backward during assembly, lower the backstop as shown.
2. Set the frame assembly onto the two "V" angles on the tripod base, and lower the frame about 1 in. until it is secured by the angles.

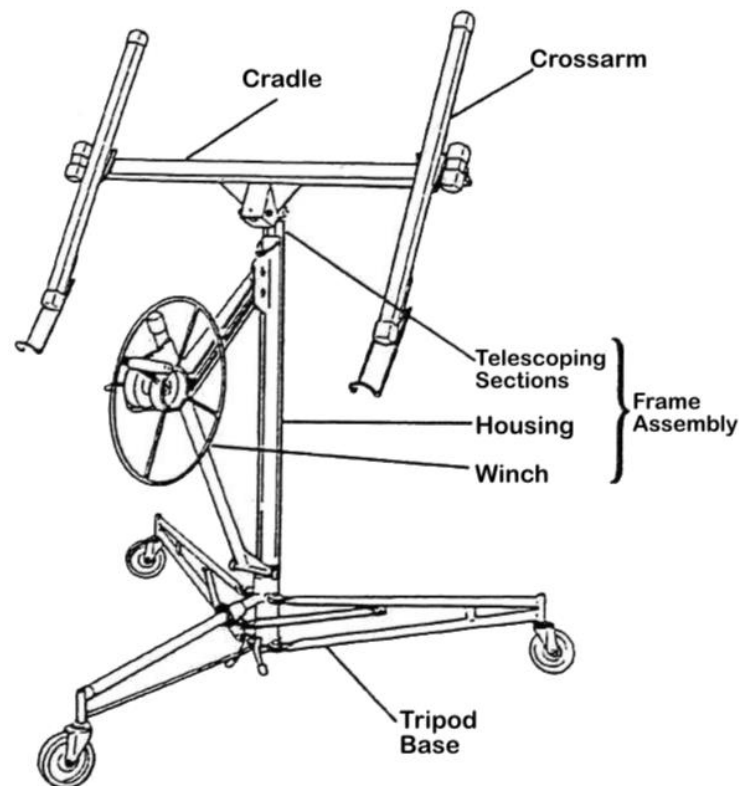

Components of Drywall Lift

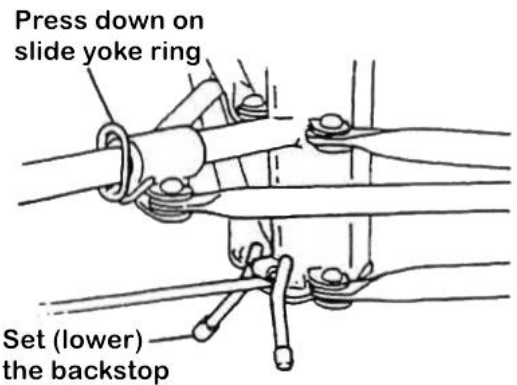
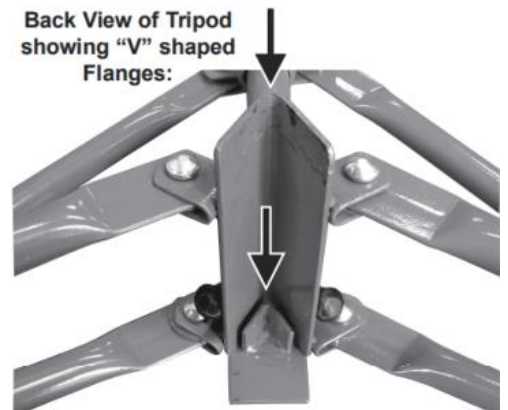

Figure 1

Set the Telescoping Asm. into the Tripod Base.



## Assembly Procedure (continued)

3. Attach the handle to the winch wheel. Tighten the nut, then back it off slightly so the handle turns freely.
4. Move the winch assembly into its working position:
  - a. Hold the winch wheel and brake arm as shown in Figure 2. Rotate the winch wheel forward slightly while you lift on the brake arm to release the brake.
  - b. Raise the brake arm all the way up. Grasp the winch post, and grip the brake arm firmly with your thumb. (Figure 3)
  - c. Place your right hand on top of the frame. Continue to grip the brake arm as needed to prevent cable backlash, and pull the winch assembly all the way toward you. (Figure 4)
  - d. When the winch is fully extended (away from the frame housing), release the brake arm and swing the retaining hook away so it no longer secures the telescoping sections inside the frame housing.
5. Press the winch assembly slightly back toward the frame. This automatically engages the slide bar lock to keep the winch fully extended. (Figure 5)

**IMPORTANT:** Before continuing, be sure that the slide bar lock is fully engaged — that is, rotated clockwise as far as possible.

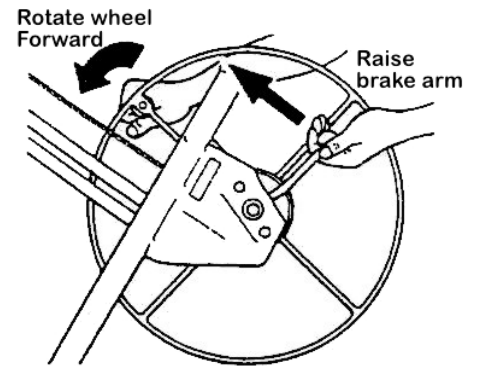

Figure 2

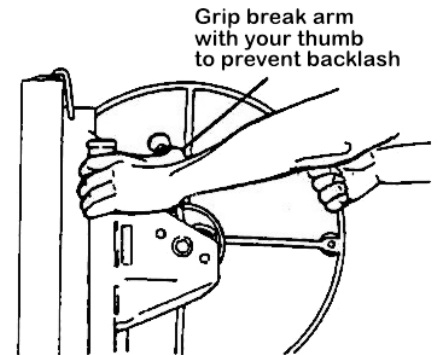

Figure 3

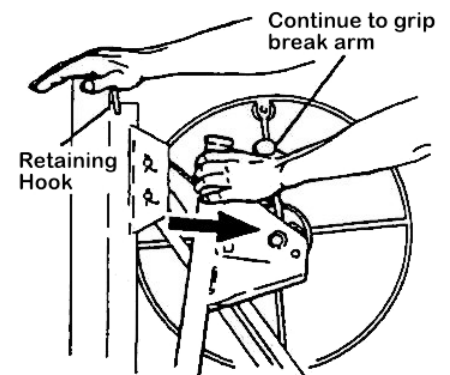

Figure 4

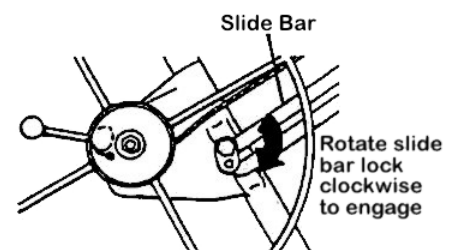
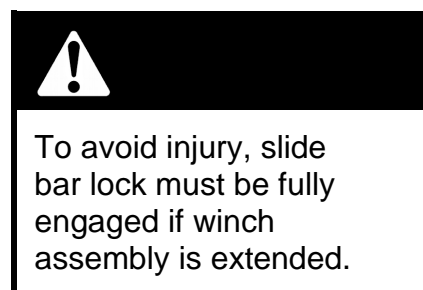

Figure 5



## Assembly Procedure (continued)

6. Attach the cradle to the frame (Figure 6):
  - a. Insert the cradle's post into the opening on top of the frame.
  - b. Secure the cradle to the frame by snapping the tilt latch upward so it hooks over the stud on the cradle.
7. Attach the crossarms to the cradle:

NOTE: The crossarms are interchangeable.

- a. Slide the tapered plates on the crossarms into the tapered sockets on the cradle. (Figure 7)
- b. Press each crossarm forward into the socket until the spring tab on the bottom of the crossarm snaps into place. (Figure 8)

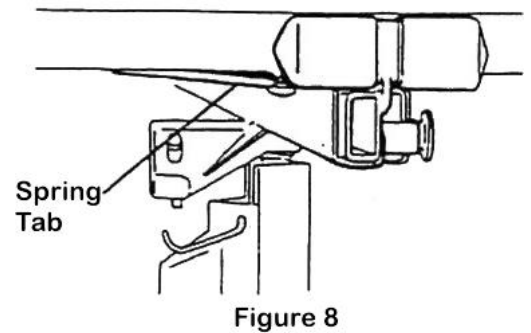
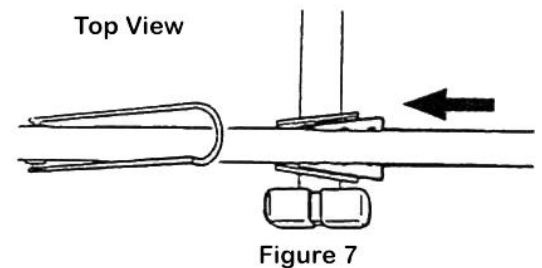
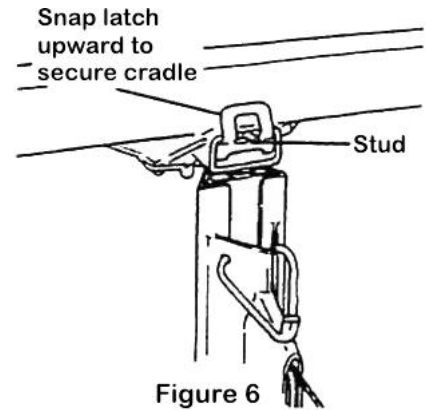

# Operator Controls

## Slide Yoke Ring

Press down on the slide yoke ring to unlatch the two forward legs so they can be rotated out to the Lift's working position or in to its storage position. A spring-loaded pin snaps into a hole on the bottom of the slide tube, to lock the folding legs position.

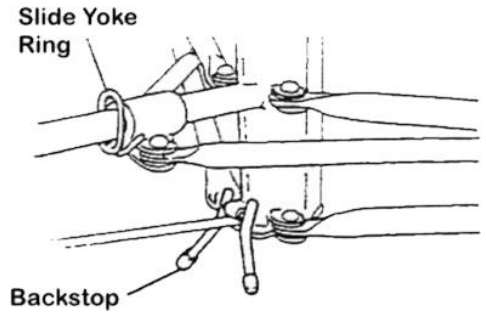

## Backstop

Pivot the backstop down to prevent the base from rolling backward, or up to allow the unit to wheel freely.

## Outriggers

The outriggers on the crossarms extend for supporting a longer drywall panel.

To extend an outrigger, pull out the lock pin with your right hand until you can slide the outrigger out with your left hand. The lock pin can engage to lock the outrigger at one of three positions: fully retracted; extended 53cm.; or extended 84cm. (see the mark)

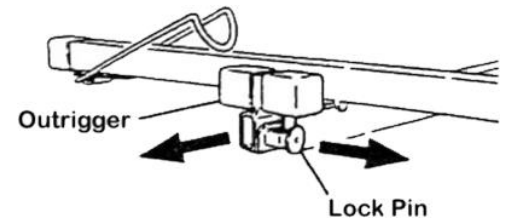

**IMPORTANT: Never load a drywall panel or operate the Lift if the lock pins are not engaged at one of these three positions, or if the outriggers are extended beyond the 56cm. position.**

To avoid damaging them, always fully retract the outriggers before transporting or storing the Lift.

## Panel Support Hooks

Open the support hook on each crossarm to support the drywall panel when it is being loaded, or when the cradle is tilted.

To avoid damaging them, always close the support hooks before transporting or storing the Lift.

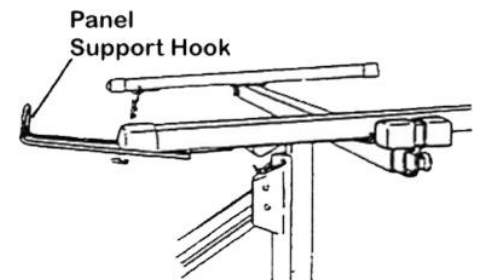

## Slide Bar Lock

The slide bar lock holds the winch assembly at its operating (fully extended) position.

To fold the winch assembly against the frame (when disassembling the unit for transport or storage), disengage the lock by turning it counterclockwise as you lift on the slide bar.

When you reassemble the unit for operation, extending the winch assembly all the way and then pressing it back slightly toward the frame automatically engages the lock.

Never tighten the nut on the slide bar lock, or you will be unable to fold up the unit for transport and storage.

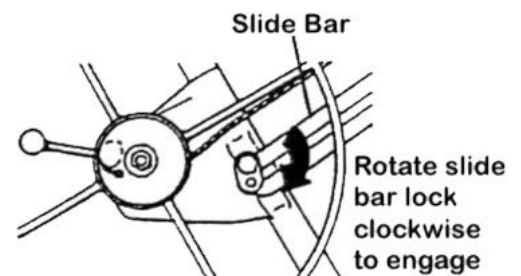

# Operator Controls (continued)

## Tilt Latch

To allow the cradle to tilt (for loading a dry wall panel, or for raising the panel to a side wall or sloped ceiling); or to remove the cradle from the frame, pivot the tilt latch out and down. To lock the cradle onto the frame without tilting, pivot the latch up to engage the stud on the cradle.

NOTE: When it is in the level (non-tilted) position, the cradle will also tilt up to 10° side-to-side.

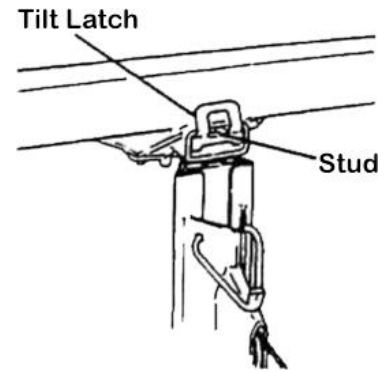

## Brake Arm

A spring-loaded brake holds the cradle at whatever height you raise it by cranking the winch wheel. To lower the cradle, control the backward rotation of the winch by grasping the wheel handle as you carefully raise the brake arm to release the brake.

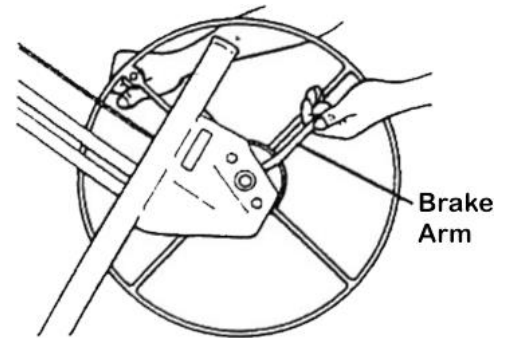

## Winch Wheel, Handle, and Post

Cranking the winch (using the wheel handle) coils or uncoils the cable that raises or lowers the cradle.

Grasp the post for leverage when cranking the winch.

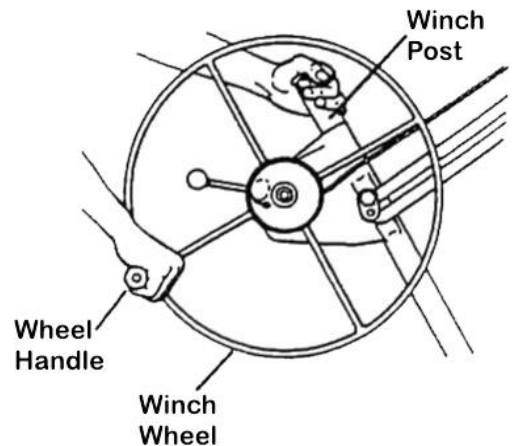

## Retaining Hook

The retaining hook secures the telescoping sections inside the frame, for transport and storage.

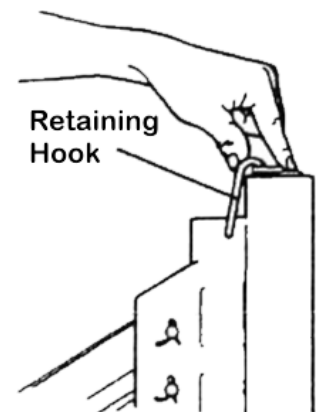

# Operating Procedure

IMPORTANT: Read the "Important Precautions" on page 3 before you operate the Lift.

## Safety Check Before Operation

Before you begin operating the Lift each day:

- Inspect the unit carefully for wear or damage. Pay special attention to the cable.
- Be sure the Lift is at working room temperature before operating.
- Be sure the winch brake drum is clean and dry before operating.

## To Load a Drywall Panel

1. Set (lower) the backstop, so the Lift won't roll backward (see page 7).
2. Swing open the panel support hooks on the two crossarms. Be sure the cradle is turned so the support hooks are on the opposite side from the winch wheel.
3. Extend the crossarm outriggers on the cradle as needed to fully support the length of the drywall panel (see page 7).
4. Release the tilt latch to tilt the cradle (see page 8).
5. Hold the drywall panel with its face paper toward the tilted cradle, and load the panel onto the Lift as shown. Set the panel onto the support hooks, and carefully lean it against the crossarms.
6. If installing the panel on a flat ceiling, tilt the cradle back up to its level position and lock the tilt latch. If installing the panel on a side wall or a sloped ceiling, leave the cradle tilted.
7. Raise the backstop on the base, and carefully roll the Lift close to the position where the panel will be installed.

  
To avoid serious injury, follow all "Important Precautions," page 3.

  
ALWAYS wear a hard hat when operating.

  
To avoid injury:  
• Use ONLY for lifting a drywall panel.  
• Lift ONLY one panel at a time.  
• NEVER lift more than 68kgs.

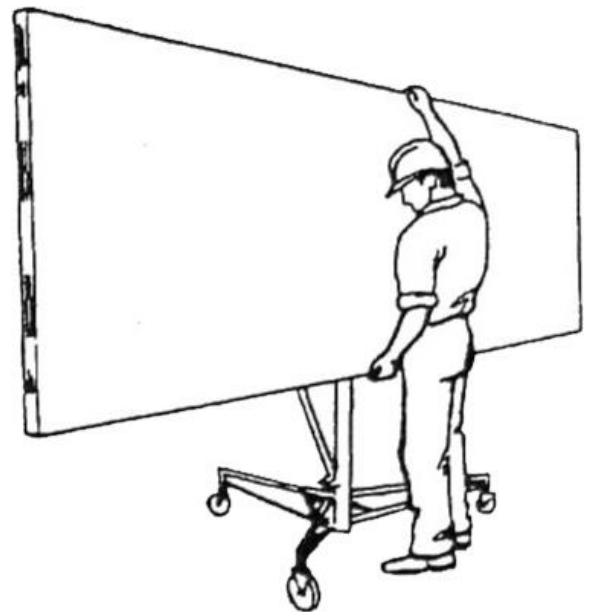

Figure 10



# Operating Procedure

## To Raise the Panel

**IMPORTANT:** Always lower the backstop before raising the panel to a sloped ceiling or a side wall.

Crank the winch wheel in the direction shown (hold the post for leverage) until the panel is at the desired height.

The brake is spring-loaded to automatically hold the cradle at the selected height when you stop cranking.

## To Lower the Panel

1. Grasp the wheel handle with your right hand so you can restrain the backward rotation of the winch.
2. Retain your hold on the winch handle. Carefully release the brake with your left hand and slowly rotate the wheel backward to lower the cradle to the desired height.

## Disassembly and Storage

Always store the On/wall Lift in a dry, protected area. To disassemble for more compact storage, refer to page 11.

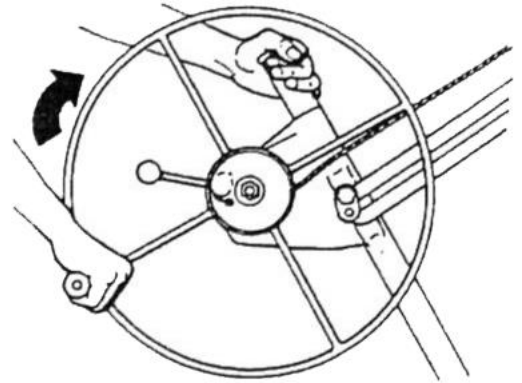

Figure 11

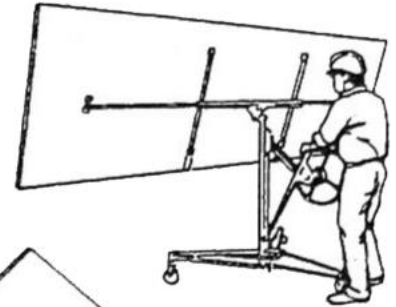

Figure 12

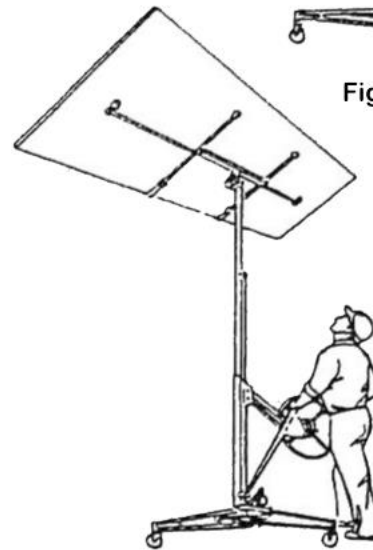
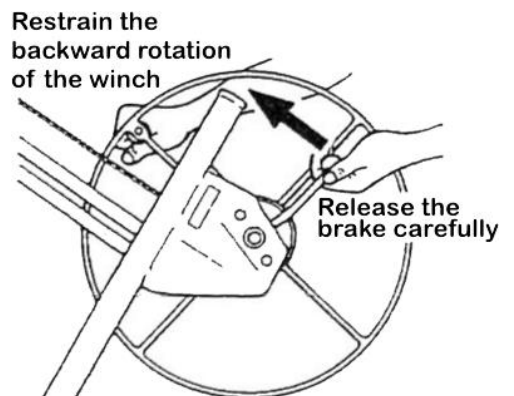
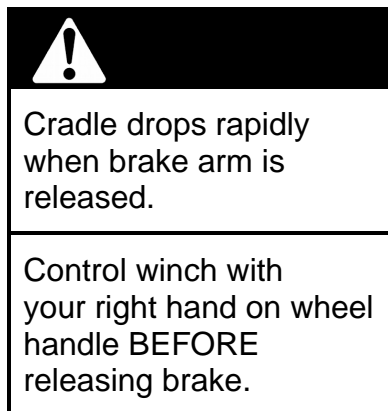
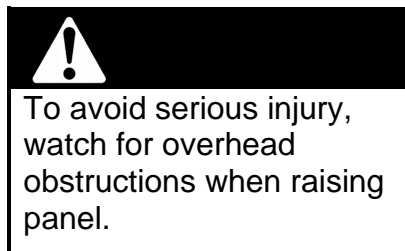

Figure 13



To Lower the Panel  
Figure 14

# Disassembly

To disassemble the Drywall Lift for transport or compact storage;

1. Crank the cradle all the way down.
2. Slide the cradle outriggers all the way in until they latch. Close the panel support hooks.
3. Remove the crossarms by pressing the spring tab on the bottom and sliding the crossarm out of the tapered socket.
4. Unlock the cradle tilt latch. Lift the cradle (about 7.5cm.) until you can remove it from the frame.
5. Rotate the winch wheel one full rotation forward as shown. This will raise the inner telescoping section.
6. Unlock the winch assembly by lifting the slide bar with your left hand while you rotate the slide bar lock counterclockwise with your right hand.
7. Hold the slide bar lock in this disengaged position (step 6) and press down on the telescoping sections in the frame with your left hand. The winch assembly will move toward the frame housing.
8. Crank the telescoping sections all the way down. Swing up the retaining hook as shown, and crank the telescoping sections back up slightly until secured by the hook.
9. Hold the retaining hook in this position with your left hand, and rotate the winch forward with your right hand.  
The winch assembly will fold up against the frame. When the slide bar contacts the frame, tighten the cable by turning the wheel further (just enough to hold the winch assembly in this position).
10. Carefully lift the frame/winch about 2.54cm. to free it from the tripod base.
11. To fold the base, press down on the slide yoke ring and pivot the forward legs in until they lock in the closed position.

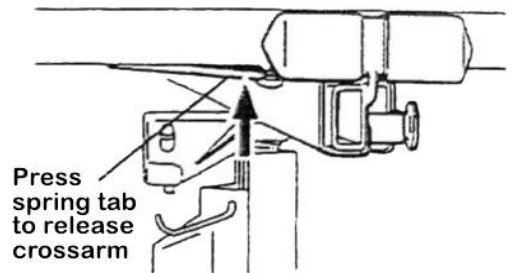

Figure 15

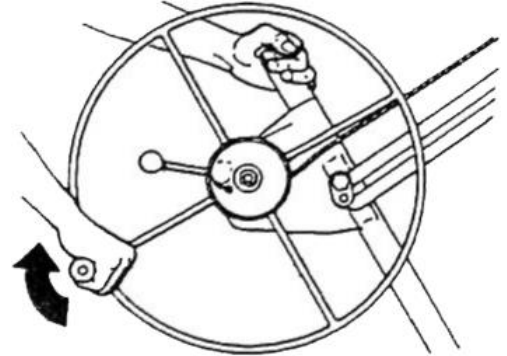

Figure 16

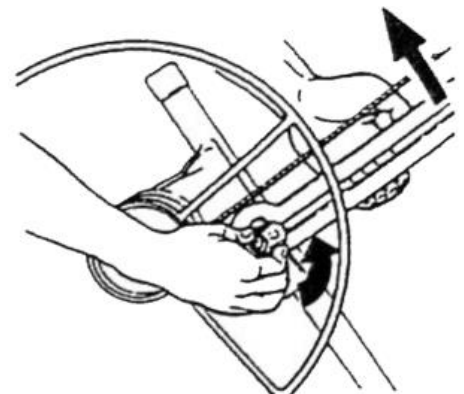

Figure 17

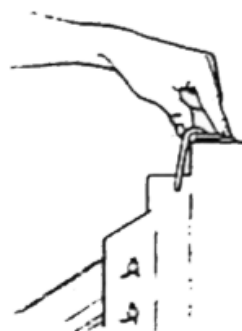

Figure 18

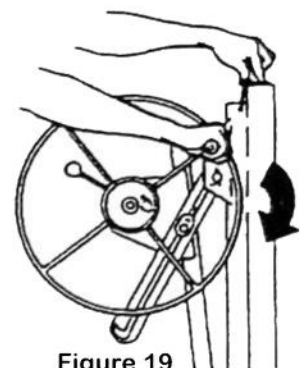

Figure 19

## Maintenance

- Inspect the cable before each work day. Replace it at the first sign of wear (refer to the instructions supplied with the replacement cable).
- Occasionally oil the cable pulleys. Crank up the telescoping sections for access to the internal cable pulley. Never allow oil or grease to contact the surface of the winch brake drum.
- Occasionally oil the caster bearings.
- If the telescoping sections of the frame don't operate smoothly, apply household paraffin to the sliding surfaces.

## Extension Accessory (sold separately)

For higher ceilings, an Extension Accessory is available that increases maximum lift to 470cm (instead of the standard 335cm).

The Accessory consists of two 182-cm telescoping sections that replace the standard 122cm sections in the frame. A longer cable is preinstalled in the telescoping sections, and must be attached to the winch drum.

### To Install the Accessory

#### Remove the Standard Telescoping Sections

1. Release the cable tension until you can loosen the cable from the mooring tab in the winch. Pull the cable out through the hole in the winch drum. (Figure 20)
2. With large pliers, grasp the top end of the two telescoping sections and lift them out of the frame housing as a unit. Pulling the free end of the cable toward the winch wheel will help raise the telescoping sections.

Remove the telescoping sections (and the cable) completely out of the frame housing.

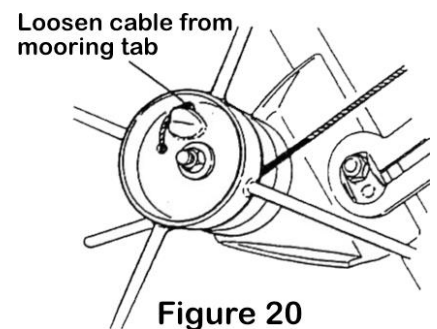

Figure 20

# Extension Accessory (Continued)

## Install the Longer Telescoping Sections

1. Feed the free (crimped) end of the Accessory's cable down into the pocket near the top the frame housing.  
**IMPORTANT:** The cable must be routed over the top of the pulley.
2. Pull the cable through the pocket, and slide the new telescoping sections down into [he frame.
3. Feed the free end of the cable under and around the winch hub, then through the hole into the winch drum.
4. Secure the crimped end of the cable firmly behind the mooring tab inside the drum.
5. Rotate the winch wheel forward to take up the slack in the cable.

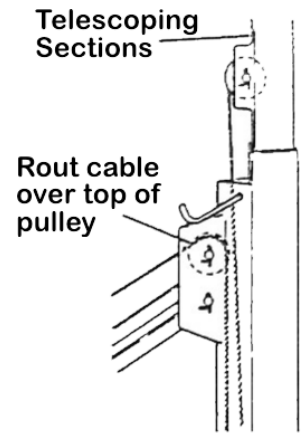

Figure 21

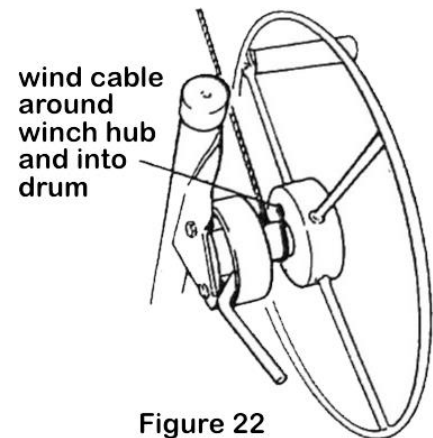
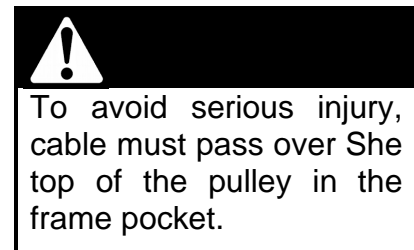

Figure 22

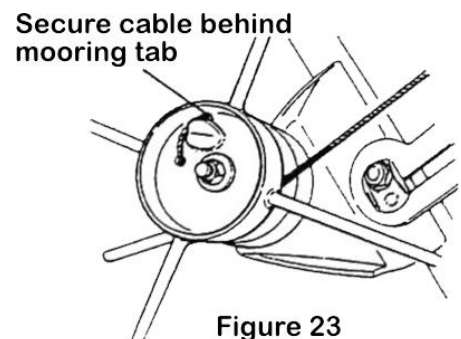
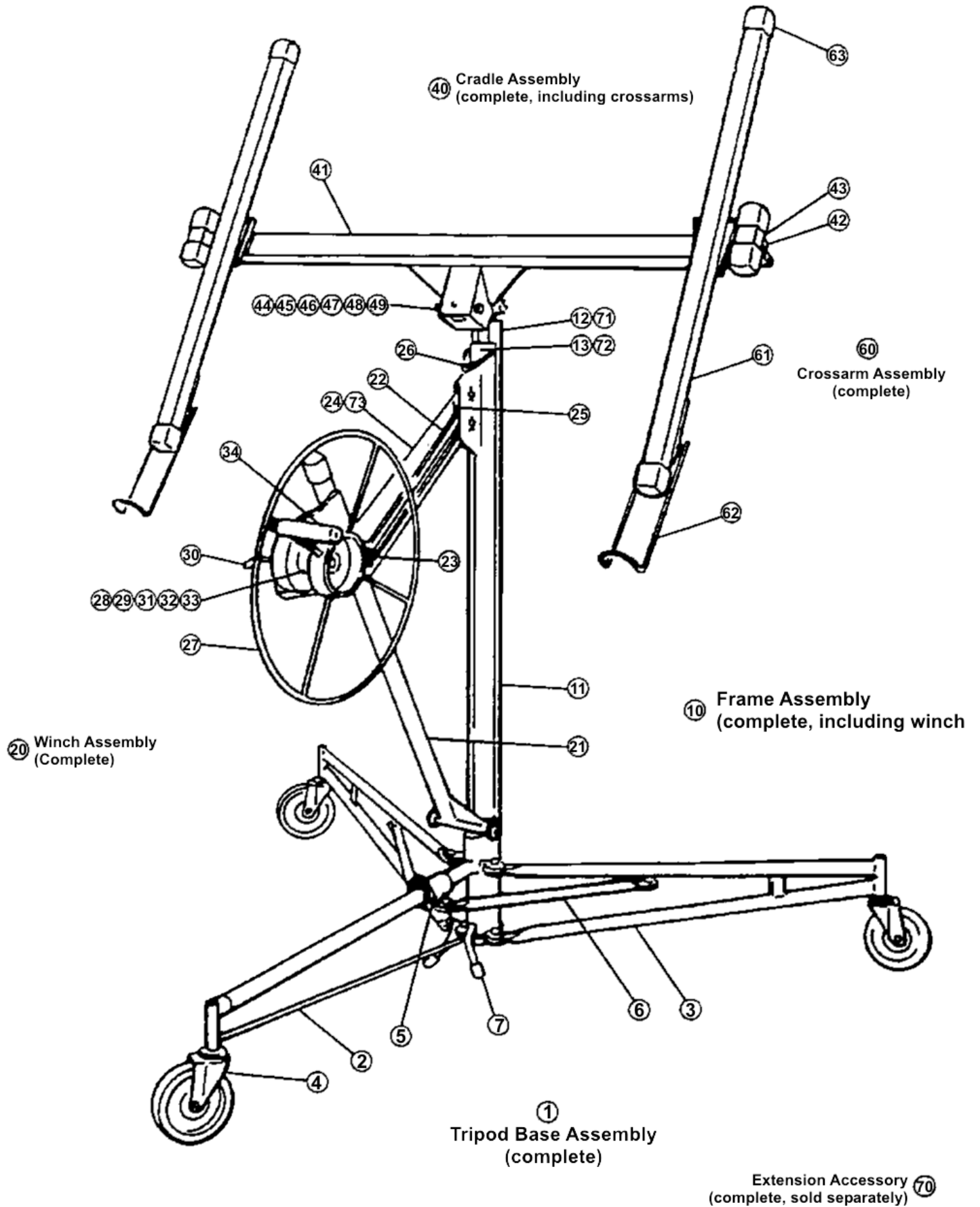

Figure 23

# Parts Diagram



# Parts List

Ref. No.	Description	Qty
<b><i>Tripod Base</i></b>		
1	Tripod base assembly	1
2	Center Leg (with fasteners)	1
3	Outer Leg (with fasteners)	2
4	10-cm Caster	3
5	Slide Yoke Ring Tension Spring	1
6	Tie Arm (with fasteners)	2
7	Rubber Backstop Tip	2

<b><i>Frame Assembly</i></b>		
10	Frame Assembly (Includes Winch Assembly)	1
11	Frame Housing	1
12	10-cm Inner Telescoping Section	1
13	10-cm Outer Telescoping Section (with pulley)	1

<b><i>Winch Assembly</i></b>		
20	Winch Assembly	1
21	Winch Host (with pin and fastener)	1
22	Slide Bar (with axle and cotter pin)	1
23	Slide Bar Lock (with fasteners)	1
24	410-cm Cable*(DIA:3..5mm)	1
25	Cable Pulley (with axle and cotter pin)	3
26	Retaining Hook	1
27	Winch Wheel (with flange bearings)	1
28	2.22-cm Bushing	1
29	M12x125 Bolt (with fasteners)	1
30	Brake Arm Assembly	1
31	Brake Lining (with fasteners)	1
32	Brake Arm Tension Spring	1
33	Brake Hub (with bolts)	1
34	Winch Wheel Handle	1

Ref. No.	Description	Qty
<b><i>Cradle Assembly</i></b>		
40	Cradle Assembly	1
41	Cradle Body	1
42	Outrigger Lock Pin (with spring & clip)	2
43	Outrigger (with end caps)	2
44	Cradle Mounting Lead Assembly	1
45	Mounting Head Body	1
46	Cradle Tilt Latch (with fasteners)	1
47	Tension Spring	1
48	Compression Spring	2
49	Hinge Pin (with bolts)	1

<b><i>Cradle Crossarms</i></b>		
60	Crossarm Assembly	2
61	Crossarm Body	2
62	Panel Support Lock (with fasteners)	2
63	Crossarm End Cap	2

<b><i>Extension Accessory (Sold Separately)</i></b>		
70	Extension Accessory	1
71	182cm Inner Telescoping Section	1
72	182cm Outer Telescoping Section	1
73	520-cm Cable*	1

\*IMPORTANT: Carefully follow the instructions supplied with the replacement cable.